

# Catifa 46

Design by Lievore Altherr Molina, 2004

## Art. 0470

Chair with chromed steel sled base, fitted with armrests. Polypropylene shell with front upholstery in leather, coated fabric, fabric or customer's own material. Optional glides with felt for wooden floors are available upon request.



## Dimensions \*

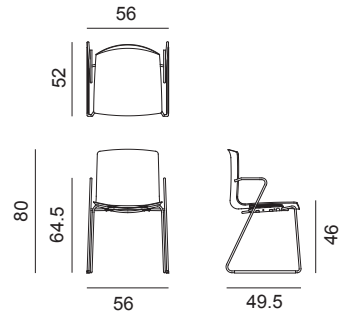

\* File CAD 2D - 3D available for download at [www.arper.com](http://www.arper.com)

## Frame Base



CRO

## Shell

### Polypropylene



PO00101 PO00104 PO00105 PO00109 PO00112 PO00113 PO00114 PO00115 PO00116 PO00117 PO00118

## Carded In



## Graded In

**kvadrat**

**camira**

**Gabriel®**

arper

info@arper.com

www.arper.com

# Catifa 46

Design by Lievore Altherr Molina, 2004

## Accessories:



Link Art. 0258



Writing tablet Art. 0264



Stacking protection pad with link Art. 0277



Stacking protection pad Art. 0499



Trolley Art. 0760

## SHIPMENT DETAILS

### Art.0470

1 pz = 2  - kg 13,32/ m<sup>2</sup> 0,326

4 pz = 2  - kg 43,12/ m<sup>2</sup> 0,456

## TECHNICAL SPECIFICATIONS

### Art.0470

COL requirement m<sup>2</sup> 0.94

H 140 cm. COM Meterage m 0.65

## RESISTANCE TEST

- EN 1728:2000 - EN 15373:2007 6.12
- EN 1728:2000 - EN 15373:2007 6.17
- EN 1728:2000 - EN 15373:2007 6.2.2
- EN 1728:2000 - EN 15373:2007 6.7
- EN 1022:05
- EN 1728:2000 - EN 15373:2007 6.15
- EN 1728:2000 - EN 15373:2007 6.2.1
- EN 1728:2000 - EN 15373:2007 6.6
- EN 1728:2000 - EN 15373:2007 6.8
- TUV GS (EN16139)

## FIRE RETARDANT TEST

## ENVIRONMENTAL CERTIFICATIONS



arper

- with stacking pad, without tools up to 8 units
- with stacking pad, with trolley up to 8 units
- with link: with stacking pad, without tools up to 8 units
- with link: with stacking pad, with trolley up to 8 units

- leather / coated fabric: with stacking pad, without tools up to 5 units
- leather / coated fabric: with stacking pad, with trolley up to 5 units
- leather / coated fabric with link: with stacking pad, without tools up to 5 units
- leather / coated fabric with link: with stacking pad, with trolley up to 5 units

- with tablet: with stacking pad, without tools up to 5 units
- with tablet: with stacking pad, with trolley up to 5 units
- with tablet with link: with stacking pad, without tools up to 5 units
- with tablet with link: with stacking pad, with trolley up to 5 units

www.arper.com

info@arper.com