

Catifa 46 Counter Stool

Design by Lievore Altherr Molina, 2013

Art. 0320

Stool with chromed or powder-coated steel sled base and white polypropylene shell (PO101) upholstered with a removable non-washable cover in leather, coated fabric, fabric or customer's own material. The cover stitching comes in the same color as the upholstery. Stitching on cover 1 and 3 comes in white or black, to customer's choice. The chair is provided already fitted with the cover. Optional glides with felt for wooden floors are available upon request. Seat height 64 cm.



Dimensions *

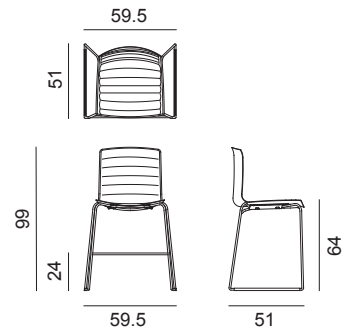

* File CAD 2D - 3D available for download at www.arper.com

Frame Base



Shell



- with stacking pad, without tools up to 8 units
- with stacking pad, with trolley up to 8 units
- leather / coated fabric: with stacking pad, without tools up to 5 units
- leather / coated fabric: with stacking pad, with trolley up to 5 units

arper

info@arper.com

www.arper.com

Catifa 46 Counter Stool

Design by Lievore Altherr Molina, 2013

Accessories:



Stacking protection pad Art.
0499



Trolley Art. 0760

SHIPMENT DETAILS

Art.0320

1 pz = 2 - kg 12,6/ m³ 0,338

4 pz = 2 - kg 43,6/ m³ 0,532

RESISTANCE TEST

- TUV GS (EN16139)

ENVIRONMENTAL CERTIFICATIONS



TECHNICAL SPECIFICATIONS

Art.0320

COL requirement m² 1.97

H 140 cm. COM Meterage m 1.08

*Classe 1, 2, 11M: fire retardant version available with surcharge and eventual minimum batch

FIRE RETARDANT TEST

arper

www.arper.com

info@arper.com