

# Kinesit

Design by Lievore Altherr Molina, 2014

## Art. 4852

Chair with powder coated aluminum 5 way swivel base on castors (available for hard and soft floors, color matching base), fitted with gas-lift mechanism for height adjustment. Seat with built-in self-tensioning weight response mechanism, backrest with 3-position recline, adjustable lumbar support breathing up to 60 mm. Back and seat completely upholstered in leather, customer's leather, coated fabric, fabric or customer's fabric. Fixed or adjustable armrests in nylon fiber, color matching backshell, are available upon request and with a surcharge. Back and seat can be ordered in different colors of the same upholstery, with a surcharge.



## Dimensions \*

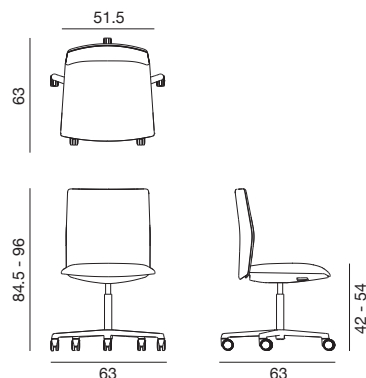

\* File CAD 2D - 3D available for download at [www.arper.com](http://www.arper.com)

## Frame Base



## Shell

arper

www.arper.com

info@arper.com

# Kinesit

Design by Lievore Altherr Molina, 2014



Armrest 2D



Armrest

## SHIPMENT DETAILS

### Art.4852

1 pz = 1  - kg 21/ m³ 0,4

## TECHNICAL SPECIFICATIONS

### Art.4852

COL requirement m² 2.44

H 140 cm. COM Meterage m 1.38

\*Classe 1, 2, 1IM: fire retardant version available with surcharge and eventual minimum batch

## RESISTANCE TEST

- ANSI/BIFMA X5.1-2011/10
- ANSI/BIFMA X5.1-2011/12
- ANSI/BIFMA X5.1-2011/14
- ANSI/BIFMA X5.1-2011/17
- ANSI/BIFMA X5.1-2011/5
- ANSI/BIFMA X5.1-2011/8
- EN 1335-3:2009 7.1
- EN 1335-3:2009 7.2.2
- EN 1335-3:2009 7.2.4
- EN 1335-3:2009 7.3.1
- EN 1335-3:2009 7.3.3
- EN 1335-3:2009 4.1
- ANSI/BIFMA X5.1-2011/11
- ANSI/BIFMA X5.1-2011/13
- ANSI/BIFMA X5.1-2011/16
- ANSI/BIFMA X5.1-2011/21
- ANSI/BIFMA X5.1-2011/6
- ANSI/BIFMA X5.1-2011/9
- EN 1335-3:2009 7.2.1
- EN 1335-3:2009 7.2.3
- EN 1335-3:2009 7.2.5
- EN 1335-3:2009 7.3.2
- EN 1335-3:2009 7.3.5

## FIRE RETARDANT TEST

## ENVIRONMENTAL CERTIFICATIONS



arper

www.arper.com

info@arper.com