

LOOP



Design by
Lievore Altherr Molina, 2009

arper

Loop

Design by Lievore Altherr Molina, 2009

Abaco di collezione

Tipo

Freestanding



Divano 2 posti

Divano 3 posti

Moduli componibili



Lineare

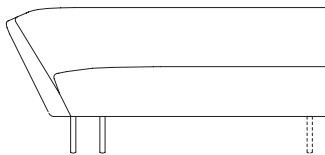
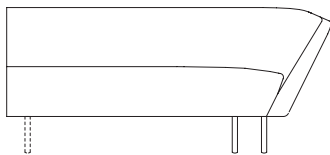
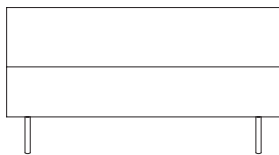

Con bracciolo destro

Con bracciolo sinistro

Angolare

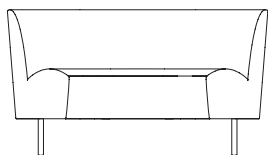
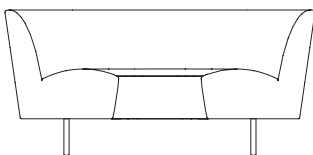

90°

135°

Loop

Design by Lievore Altherr Molina, 2009

Moduli per composizioni circolari

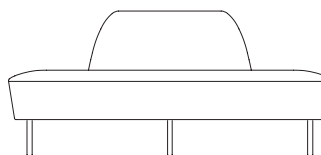
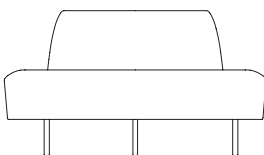
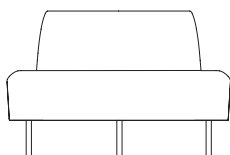
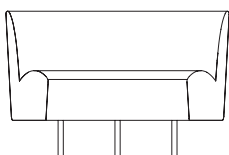

30° concavo

30° convesso

45°

90°

arper

Opzioni



— Piede in alluminio lucido o verniciato



USB



— Cuscino

info@arper.com

www.arper.com

Loop

Design by Lievore Altherr Molina, 2009

Finiture Moduli

Struttura base



LU1



S03



V39 - matt

Rivestimento

I prodotti Arper possono essere rivestiti con un'ampia scelta di tessuti, ognuno dei quali disponibili in diverse colorazioni.

Clicca [qui](#) per scoprire tutte le possibilità.

arper

info@arper.com

www.arper.com

Loop

Design by Lievore Altherr Molina, 2009

Esempi di configurazioni possibili

A
ART. 2802 + ART. 2809 + ART. 2805

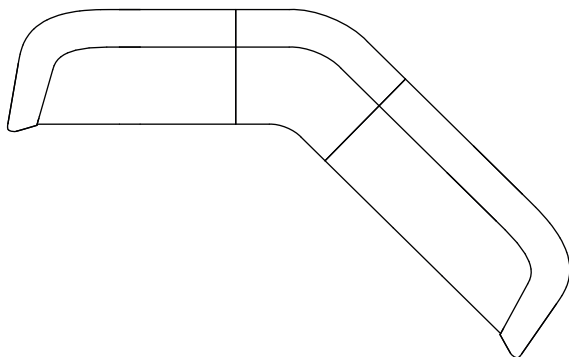

B
ART. 2802 + ART. 2805

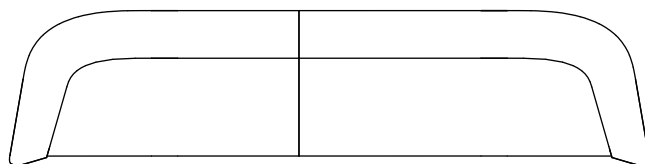

C
ART. 2802 + ART. 2807 + ART. 2803

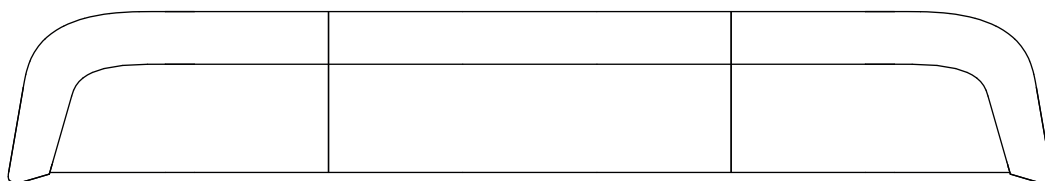

D
ART. 2804 + ART. 2808 + ART. 2809 + ART. 2807 + ART. 2803

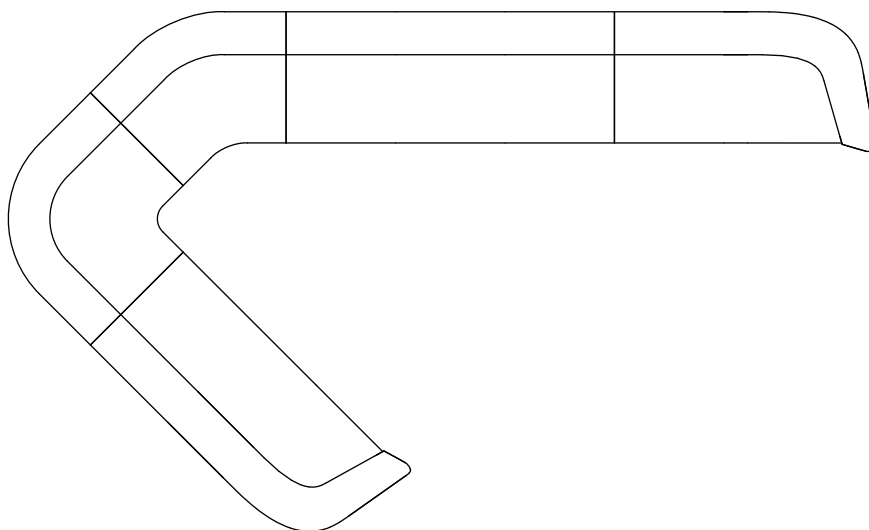

arper

info@arper.com

www.arper.com

Loop

Design by Lievore Altherr Molina, 2009

E

1x ART. 2802 + 6x ART. 2820 + 3x ART. 2821 + 2x ART. 2822 + 1x ART. 2803

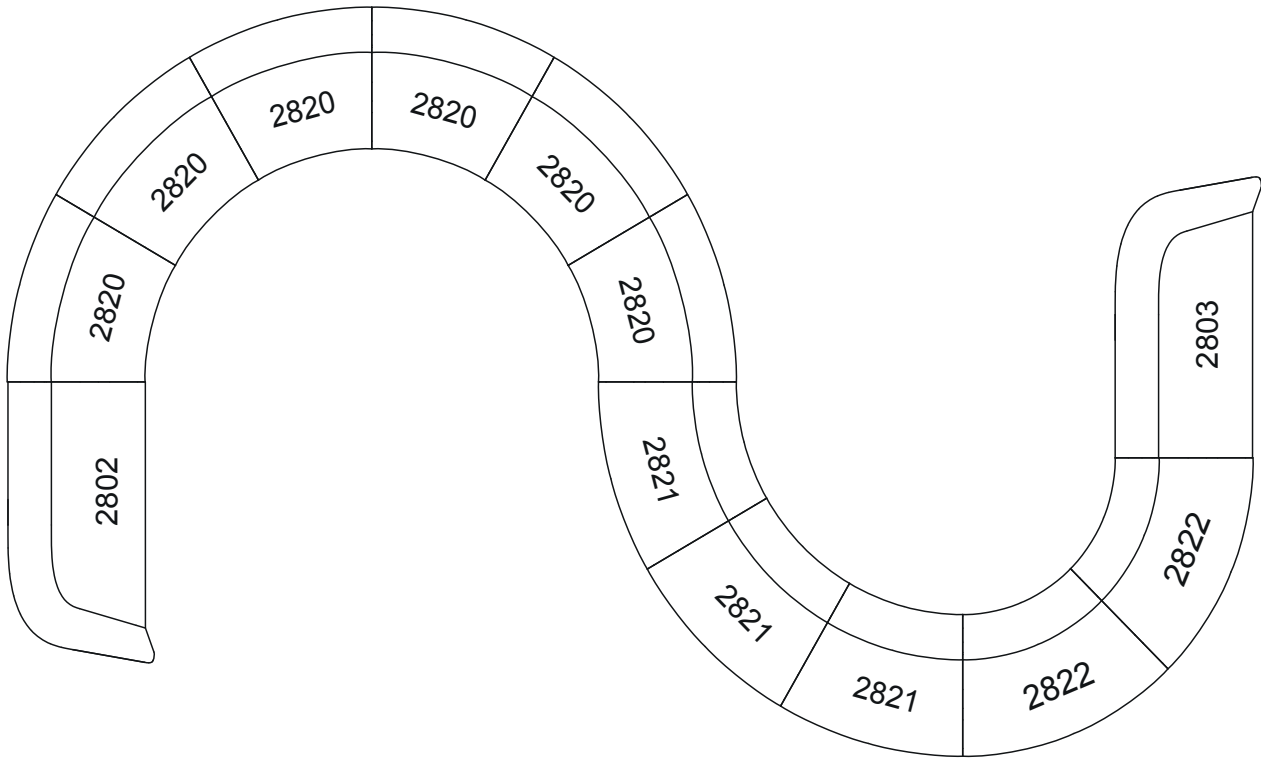

F

2x ART. 2823 + 6x ART. 2821

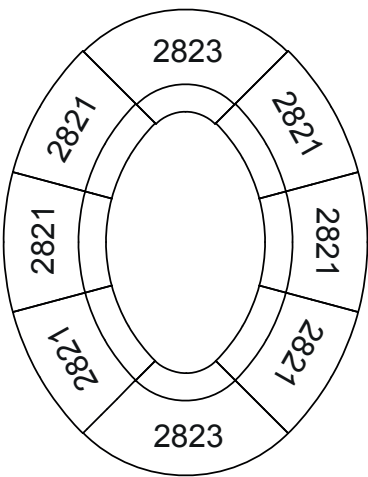

G

12x ART. 2821

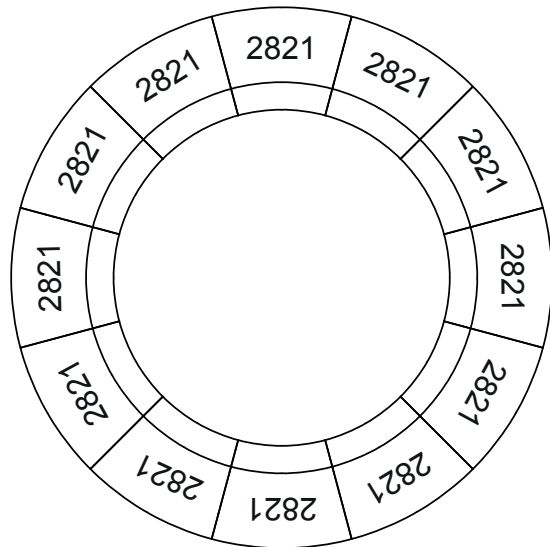

arper

info@arper.com

www.arper.com

Loop

Design by Lievore Altherr Molina, 2009

— SCHEMA CUCITURE MODULI
— SCHEMA CERNIERE MODULI

ART.	tessuto non sfoderabile	tessuto sfoderabile/spalmato	pelle
2800			
2801			
2802			
2803			
2804			
2805			
2806			

arper

info@arper.com

www.arper.com

Loop

Design by Lievore Altherr Molina, 2009

ART.	tessuto non sfoderabile	tessuto sfoderabile/spalmato	pelle
2807			
2808			
2809			
2820			
2821			
2822			
2823			

arper

info@arper.com

www.arper.com

Loop

Design by Lievore Altherr Molina, 2009

Disegni Tecnici

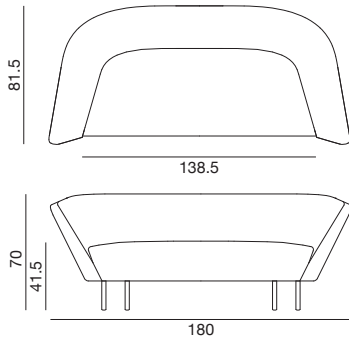

Art. 2800

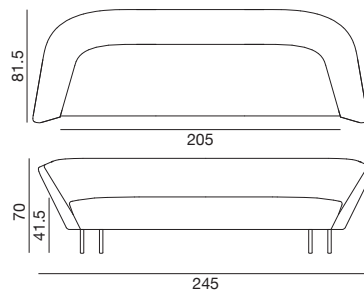

Art. 2801

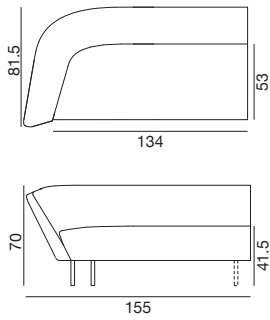

Art. 2802

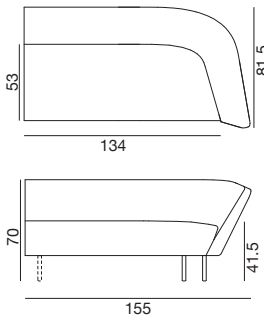

Art. 2803

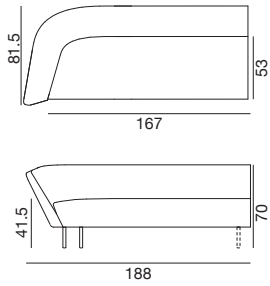

Art. 2804

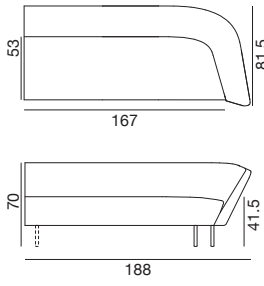

Art. 2805

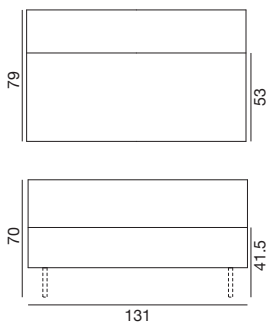

Art. 2806

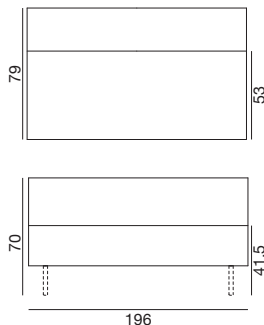

Art. 2807

arper

www.arper.com info@arper.com

Loop

Design by Lievore Altherr Molina, 2009

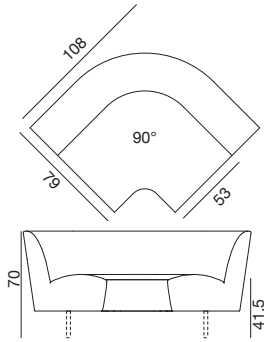

Art. 2808

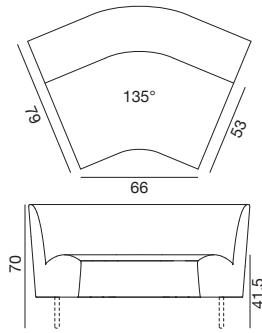

Art. 2809

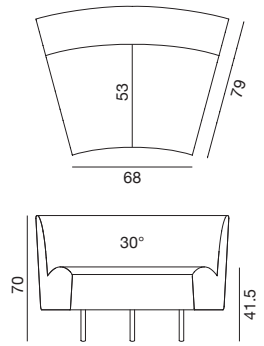

Art. 2820

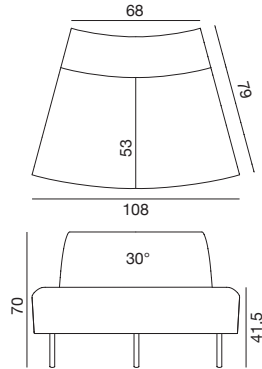

Art. 2821

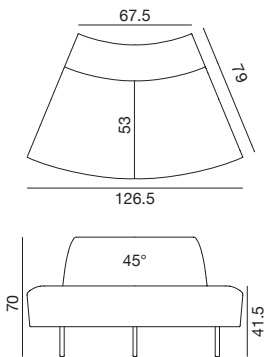

Art. 2822

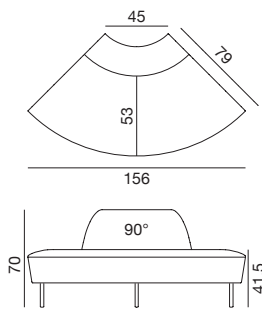

Art. 2823

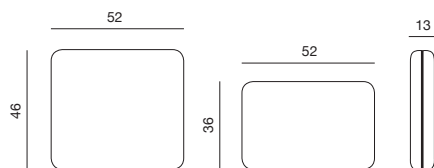

Art. 2828 + 2829

arper

info@arper.com

www.arper.com

Loop

Design by Lievore Altherr Molina, 2009

Specifiche di spedizione

Art. 2800: 1 pz =2 box – kg 55 / m3 1,195
Art. 2801: 1 pz =1 box – kg 80 / m3 1,524
Art. 2802: 1 pz =1 box – kg 44 / m3 0,997
Art. 2803: 1 pz =1 box – kg 44 / m3 0,997
Art. 2804: 1 pz =1 box – kg 54 / m3 1,179
Art. 2805: 1 pz =1 box – kg 54 / m3 1,179
Art. 2806: 1 pz =1 box – kg 42,5 / m3 0,755
Art. 2807: 1 pz =1 box – kg 64 / m3 1,1
Art. 2808: 1 pz =1 box – kg 48 / m3 1,114
Art. 2809: 1 pz =1 box – kg 42 / m3 0,899
Art. 2820: 1 pz =1 box – kg 27 / m3 0,845
Art. 2821: 1 pz =1 box – kg 27 / m3 0,845
Art. 2822: 1 pz =1 box – kg 42 / m3 0,845
Art. 2823: 1 pz =1 box – kg 30 / m3 0,845
Art. 2828: 1 pz =1 box – kg 2 / m3 0,078
Art. 2829: 1 pz =1 box – kg 5 / m3 0,153

Test di resistenza

Art. 2800, 2801, 2802, 2803

EN 1728:2012 - EN 16139:2013 6.10
EN 1728:2012 - EN 16139:2013 6.15
EN 1728:2012 - EN 16139:2013 6.17
EN 1728:2012 - EN 16139:2013 6.20
EN 1728:2012 - EN 16139:2013 6.25
EN 1728:2012 - EN 16139:2013 6.4
EN 1728:2012 - EN 16139:2013 6.6

EN 1728:2012 - EN 16139:2013 6.11
EN 1728:2012 - EN 16139:2013 6.16
EN 1728:2012 - EN 16139:2013 6.18
EN 1728:2012 - EN 16139:2013 6.24
EN 1728:2012 - EN 16139:2013 6.26
EN 1728:2012 - EN 16139:2013 6.5

Art. 2800

EN 1728:2012 - EN 16139:2013 6.27.1
EN 1022:2018 7.2

Caratteristiche tecniche

Art. 2800: COL requirement m2 10.86 — COM H 140 cm Meterage m 5.17
Art. 2801: COL requirement m2 14.29 — COM H 140 cm Meterage m 6.61
Art. 2802: COL requirement m2 9.44 — COM H 140 cm Meterage m 4.16
Art. 2803: COL requirement m2 9.44 — COM H 140 cm Meterage m 4.16
Art. 2804: COL requirement m2 10.66 — COM H 140 cm Meterage m 4.84
Art. 2805: COL requirement m2 10.66 — COM H 140 cm Meterage m 4.84
Art. 2806: COL requirement m2 7.28 — COM H 140 cm Meterage m 3.54
Art. 2807: COL requirement m2 9.53 — COM H 140 cm Meterage m 5.01
Art. 2808: COL requirement m2 7.93 — COM H 140 cm Meterage m 3.96
Art. 2809: COL requirement m2 6.89 — COM H 140 cm Meterage m 3.81
Art. 2820: COL requirement m2 6.5 — COM H 140 cm Meterage m 2.81
Art. 2821: COL requirement m2 6.06 — COM H 140 cm Meterage m 2.64
Art. 2822: COL requirement m2 6.11 — COM H 140 cm Meterage m 2.88
Art. 2823: COL requirement m2 6.24 — COM H 140 cm Meterage m 3.17
Art. 2828: COL requirement m2 1.16 — COM H 140 cm Meterage m 0.69
Art. 2829: COL requirement m2 0.9 — COM H 140 cm Meterage m 0.68

Test ignifughi

Classe 1IM Omologazione Italia

Field Kvadrat, Steelcut 2 Kvadrat, Valencia Spradling

arper

info@arper.com

www.arper.com

Italy

Monastier (TV) — Headquarters
and showroom
Arper SPA
Via Lombardia 16
31050 Monastier di Treviso (TV)
T +39 0422 7918
info@arper.com
www.arper.com

Commerciale Italia
T +39 0422 791905
commerciale@arper.com

Export Office
sales@arper.com

Milan — Showroom
Via Pantano 30
20122 Milan
T +39 02 89093865
milano@arper.com

EUROPE

UK

London — Subsidiary and showroom
Arper UK LTD
11 Clerkenwell Road
London EC1M 5PA
T +44 (0) 20 7253 0009
london@arper.com

Germany

Cologne — Showroom
Design Post Köln
Deutz-Mülheimer-Str. 22a
50679 Köln
T +49 221 690 650
info@designpost.de

Fruchtof München — Meeting Hub
2. Innenhof, 2. Etage
Gotzinger Straße 52b
D-81371 München
T +49 171 1080976
muenchen@arper.com

Norway

Oslo — Showroom
Drammensveien 130
0277 Oslo
T +47 908 202226
norway@arper.com

Sweden

Stockholm — Branch
T +46 705 101216
sweden@arper.com

The Netherlands

Amsterdam — Showroom
Design Post
Cruquiusweg 111-L
1019 AG Amsterdam
T +31 (0)20 705 1555
holland@arper.com

AMERICA

USA

New York — Subsidiary and showroom
Arper USA Inc.
476 Broadway, Suite 2F
NY 10013 New York
T +1 (212) 647 8900
infousa@arper.com

Chicago — Showroom
The Merchandise Mart
Space#346 - 3rd Floor
Chicago
T +1 (336) 434 2366
infousa@arper.com

High Point, North Carolina — Production
and logistics site
660 Southwest St
High Point, NC 27260
T +1 (336) 434 2370
infousa@arper.com

Los Angeles — Showroom
550 South Hope St., Suite 275
90071 Los Angeles
T +1 (336) 434 2382
infousa@arper.com

Mexico

Mexico City — Subsidiary and showroom
Culiacan 123, Piso 9
Col. Hipodromo Condesa
Delegation Cuauhtémoc
06170 – Ciudad de México
Mexico
T +52 1 62714417
infolatam@arper.com

ASIA

Japan

Arper Japan K.K. — Subsidiary
and showroom
HT Jingu Gaien Bldg.8F
Minato-ku Kita-Aoyama 2-7-22
Tokyo 107-0061
T +81 3 5775 0008
carejpn@arper.com

China

Shanghai — Subsidiary
爱尔派 (上海) 家具设计有限公司
2nd Floor, Unit N204-207,
Building N1,
The Bund Finance Center,
558 Zhongshan NO.2 Road(E),
Shanghai
T +86 021 5466 7366
china@arper.com

Singapore

Singapore — Branch
c/o 3 Lim Teck Kim Road, #01-01
Genting Centre
088934 Singapore
singapore@arper.com

UAE

Arper Middle East and India
— Subsidiary
and showroom
U-Bora Towers - Unit 1901
Business Bay
Dubai
T +971 529255633
infome@arper.com